

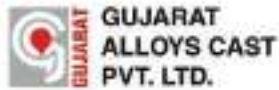

SAND CASTING

ALFA FOUNDRY TECHNOLOGIES PVT. LTD.

CLIENTS



ABOUT US

With A Legacy of more than 35 years in the foundry industry. **ALFA ENGINEERING AND ENTERPRISE (AEE)** has made a constant progress as a Foundry Machinery Manufacturer since 2008.

Alfa Engineering & Enterprise is backed by nearly half decades of experience besides of various type of Mr. Dhanjibhai Raiyani.

We offer entire range of equipments used in foundry industry where sand is used in process. We are involved in the production of machines and system for the process of chemical bonded sand (No Bake), and Green Sand Process.

AEE prime equipment supplier that designs and manufactures a wide range of foundry equipments.

We believe in providing continuous support to our clients by providing the highest level of technical guidance from a highly trained team of experts with strong professional communication.

AEE moved forward and added more feather in its cap. From 1st April 2022 ALFA ENGINEERING AND ENTERPRISE known as **ALFA FOUNDRY TECHNOLOGIES PVT.LTD. (AFTPL)**

AFTPL have young technical support by Mr. Gaurav Raiyani from 2012.

AFTPL think **"QUALITY ALWAYS COMES WITH COST"**

But we always trying to provide technology in cost effective terms.Because AFTPL work on the philosophy of **"TECHNOLOGY TEMPLE"**



MIZRAKA

(मिश्रक) Series Continuous Mixer

Sand Casting Equipments
NO BAKE PROCESS

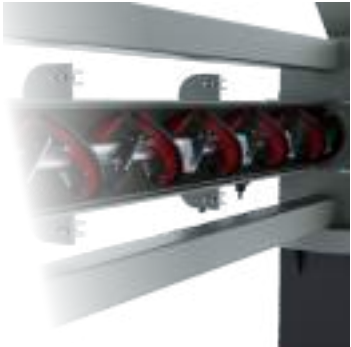



Features

- ✓ Hard faced wear resistance mixing blade.
- ✓ Non metallic catalyst pump for furan system.
- ✓ Perfect designed spraying system for better mixing quality.
- ✓ Easy to clean design.
- ✓ All chemical setting can be changed at operator control station.

MIZARKA SERIES CONTINUOUS MIXER

Model	Through Output	Connected Power	
		Mixing Screw	Pump Drive
MIZRAKA - 3	3TPH	2.2 KW	0.55 KW
MIZRAKA - 6	6TPH	3.7 KW	0.55 KW
MIZRAKA - 10	10TPH	5.5 KW	0.55 KW
MIZRAKA - 20	20TPH	11 KW	0.55 KW
MIZRAKA - 30	30TPH	18.5 KW	0.55 KW



NO BAKE SCREW ARCTIC CONTINUOUS SAND MIXER

Sand Casting Equipments
NO BAKE PROCESS

Mizraka - DA (मिश्रक) Series

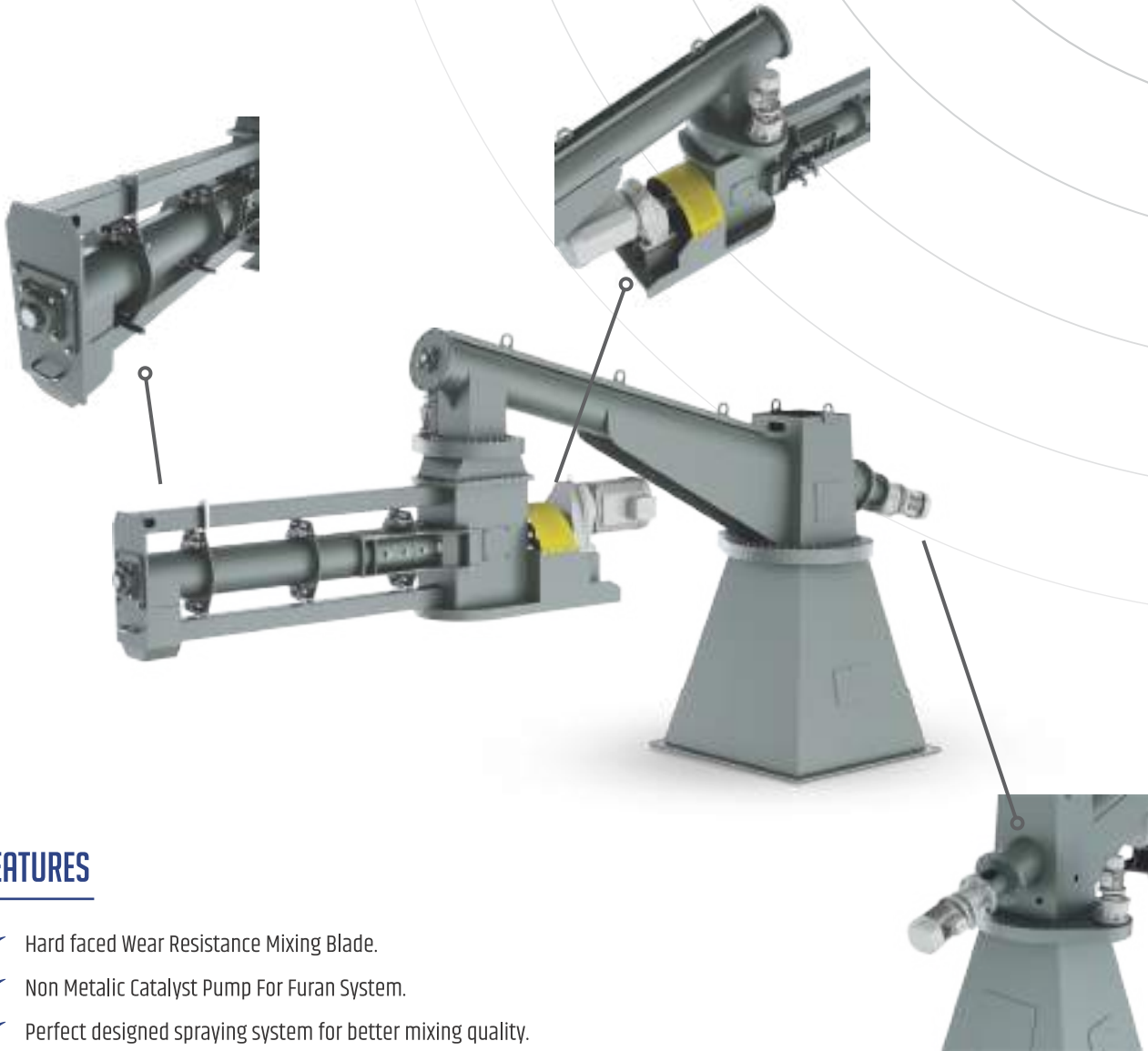

FEATURES

- ✓ Hard faced Wear Resistance Mixing Blade.
- ✓ Non Metallic Catalyst Pump For Furan System.
- ✓ Perfect designed spraying system for better mixing quality.
- ✓ Easy To Clean Design.- All Chemical Setting Can Be Changed At Operator Control Station.
- ✓ Mixer And Jib Rotation Is Motor Driven.

MIZARKA-DA SERIES SCREW ARCTIC CONTINUOUS MIXER

Model	Through Output	Connected Power		
		Mixing Screw	Feeding Screw	PUMP DRIVE
MIZARKA-DA-10	10TPH	5.5KW	2.2KW	0.55 KW
MIZARKA-DA-20	20TPH	11KW	2.2KW	0.55 KW
MIZARKA-DA-30	30TPH	18.5 KW	3.7 KW	0.55 KW



COMPACTION TABLE

Sand Casting Equipments
NO BAKE PROCESS

FEATURES

- ✓ Available in different models.
- ✓ Used for moulds mechanical strength gain.
- ✓ AFTPL provide adjustable vibration by VFD.



ROLL-OVER

FEATURES

- ✓ AFTPL Roll over unit have advance hydraulic rotating system for smooth rotation.
- ✓ It comes with stripping vibrating facility.
- ✓ Stripping movement through single hydraulic cylinder for precise stripping.
- ✓ Robust design and perfectly material selection for industrial environment.



PRE KNOCKOUT

Sand Casting Equipments
NO BAKE PROCESS

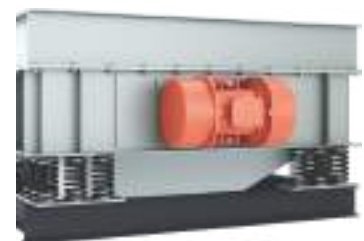
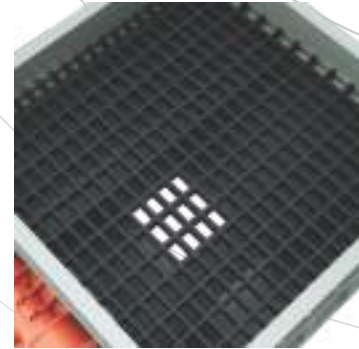

FEATURES

- ✓ Pre-knockout used for CONVERT the mould in TO small lumps.
- ✓ It comes with different in size and loading capacity.
- ✓ Robust design.
- ✓ Material contact area covered by wear resistance material for better life.



VIBRO FEEDER

Sand Casting Equipments
NO BAKE PROCESS

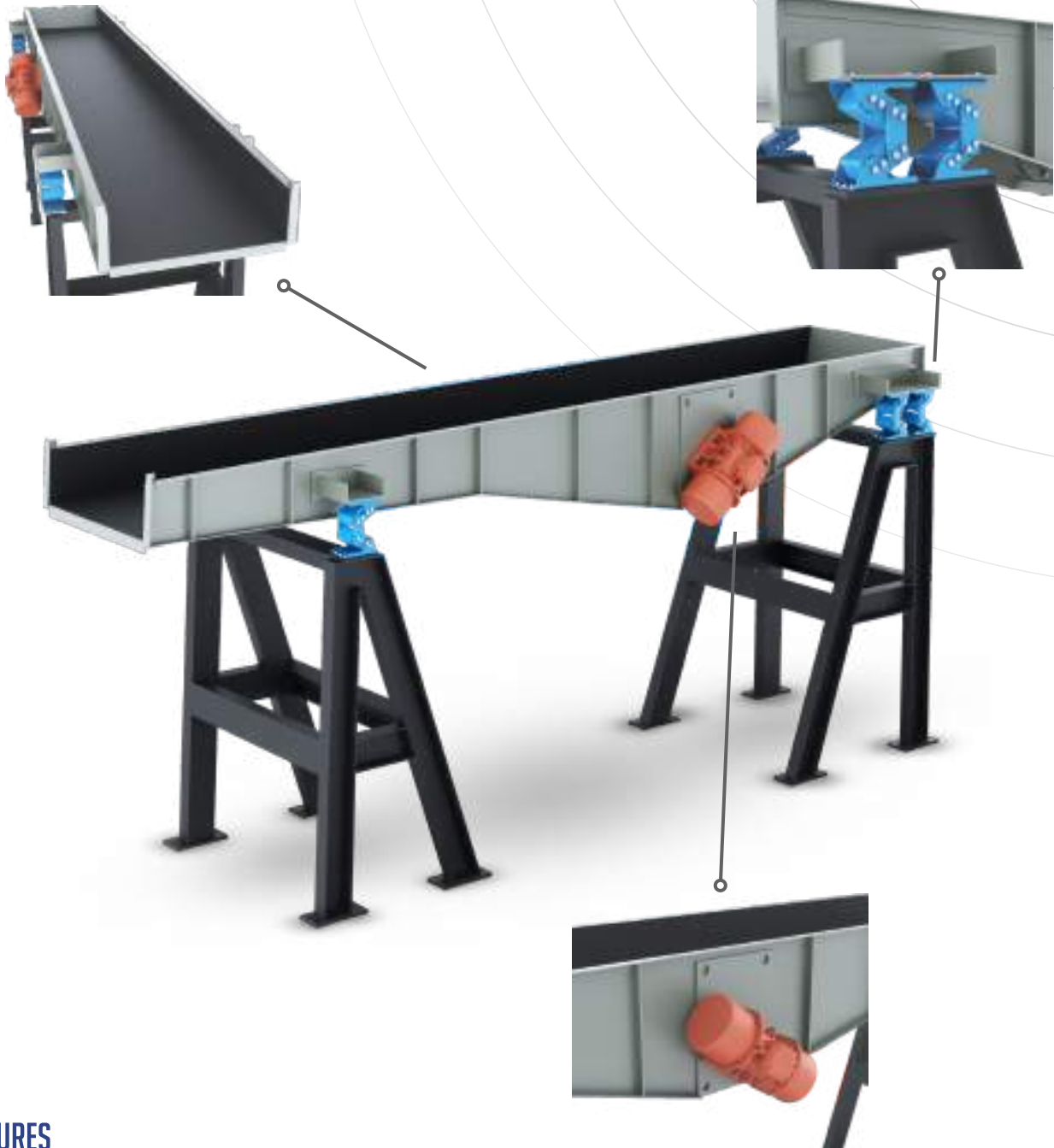

FEATURES

- ✓ Used for conveying lumps from Pre-Knockout to Mechanical reclamation system.
- ✓ Contact area covered by wear resistance material for better life.
- ✓ Robust design.
- ✓ It comes with different in size as per customer needs.



SAND RECLAMATION SYSTEM

Mahat (महत) Series

Sand Casting Equipments
NO BAKE PROCESS



FEATURES

- ✓ Designed to receive lumps via conveyor loader.
- ✓ Discharge sand at an elevated height.
- ✓ Six models are available.

MAHAT SERIES HIGH LEVEL KNOCKOUT

Model	Through Output	Duck Size	Connected Power
MAHAT - 3	3 TPH	800 mm X 1000 mm	3.8 KW
MAHAT - 6	6 TPH	925 mm X 1200 mm	4.3 KW
MAHAT - 9	9 TPH	925 mm X 1200 mm	6.2 KW
MAHAT - 12	12TPH	1150mm X 1500mm	6.4 KW
MAHAT - 15	15TPH	1150mm X 1500mm	11.96 KW
MAHAT - 20	20TPH	1500mm X 2000mm	11.96 KW



SAND RECLAMATION LOW LEVEL KNOCKOUT

Sand Casting Equipments
NO BAKE PROCESS

Nyuna (न्यूना) Series



FEATURES

- ✓ Through output from 3 to 9 tph.
- ✓ Coarse screen 32% opening are for better output.
- ✓ SS wedge wire screen.
- ✓ Easily replaceable screen.

NYUNA SERIES LOW LEVEL KNOCKOUT

Model	Through Output	Duck Size	Connected Power
NYUNA - 3	3 TPH	1000MM X 1000MM	2 X 3.8 KW
NYUNA - 6	6 TPH	1200MM X 1200MM	2 X 4.3 KW
NYUNA - 9	9 TPH	1500MM X 1500MM	2 X 6.2 KW



SAND RECLAMATION SYSTEM COOLER CLASSIFIER

Zitaka (शीतक) Series

Sand Casting Equipments
NO BAKE PROCESS



FEATURES

- ✓ Inbuilt radiator for sand cooling.
- ✓ Outlet sand temperature is ambient +7°c.
- ✓ Blower for fluidization and dust removing.

ZITAKA SERIES COOLER CLASSIFIER

Model	Through Output	CONNECTED POWER	WATER
ZITAKA - 3	3 TPH	7.5KW	364LPM
ZITAKA - 6	6 TPH	15KW	568LPM
ZITAKA - 9	9 TPH	22KW	682LPM
ZITAKA - 12	12TPH	37KW	796LPM
ZITAKA - 15	15TPH	2 X 22KW	955LPM
ZITAKA - 20	20TPH	2 X 30KW	1320LPM



PNEUMATIC SAND CONVEYING SYSTEM

Sand Casting Equipments
NO BAKE PROCESS

Vahak (वाहक) Series



FEATURES

- ✓ Fully automatic sand conveying system.
- ✓ Low conveying pressure.

VAHAK SERIES PNEUMATIC SAND CONVEYING SYSTEM

Model	Through Output	LINE SIZE
VAHAK - 3	3 TPH	80MM 3"
VAHAK - 6	6 TPH	100MM 4"
VAHAK - 9	9 TPH	125MM 5"
VAHAK - 12	12TPH	150MM 6"
VAHAK - 15	15TPH	150MM 6"



INTENSIVE MIXER

Mizraka (मिश्रक) Series

Sand Casting Equipments
GREEN SAND PROCESS

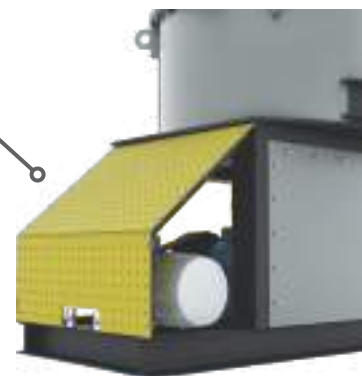

FEATURES

- ✓ Scrapper Blade With Carbide Tips.
- ✓ Bottom & Side Wall Covered By Ceramic Lining.
- ✓ High Output RPM For Better Mixing.

MIRZAKA SERIES INTENSIVE MIXER

Model	BATCH CAPACITY	BATCH TIME	CONNECTED POWER
MIZRAKA - 250	250KG	120 SEC	24 KW
MIZRAKA - 500	500KG	120 SEC	48 KW



GREEN SAND SHAKEOUT

Sand Casting Equipments
GREEN SAND PROCESS



FEATURES

- ✓ Electric vibrator
- ✓ Oscillating mounting.
- ✓ Size & capacity as per customer requirement.

SHAKEOUT

Deck Size	Connected Power
1000MM X 1000MM	2 X 1.1 KW
1200MM X 1200MM	2 X 1.1 KW
1400MM X 1400MM	2 X 1.6 KW



BELT CONVEYOR

Sand Casting Equipments
GREEN SAND PROCESS

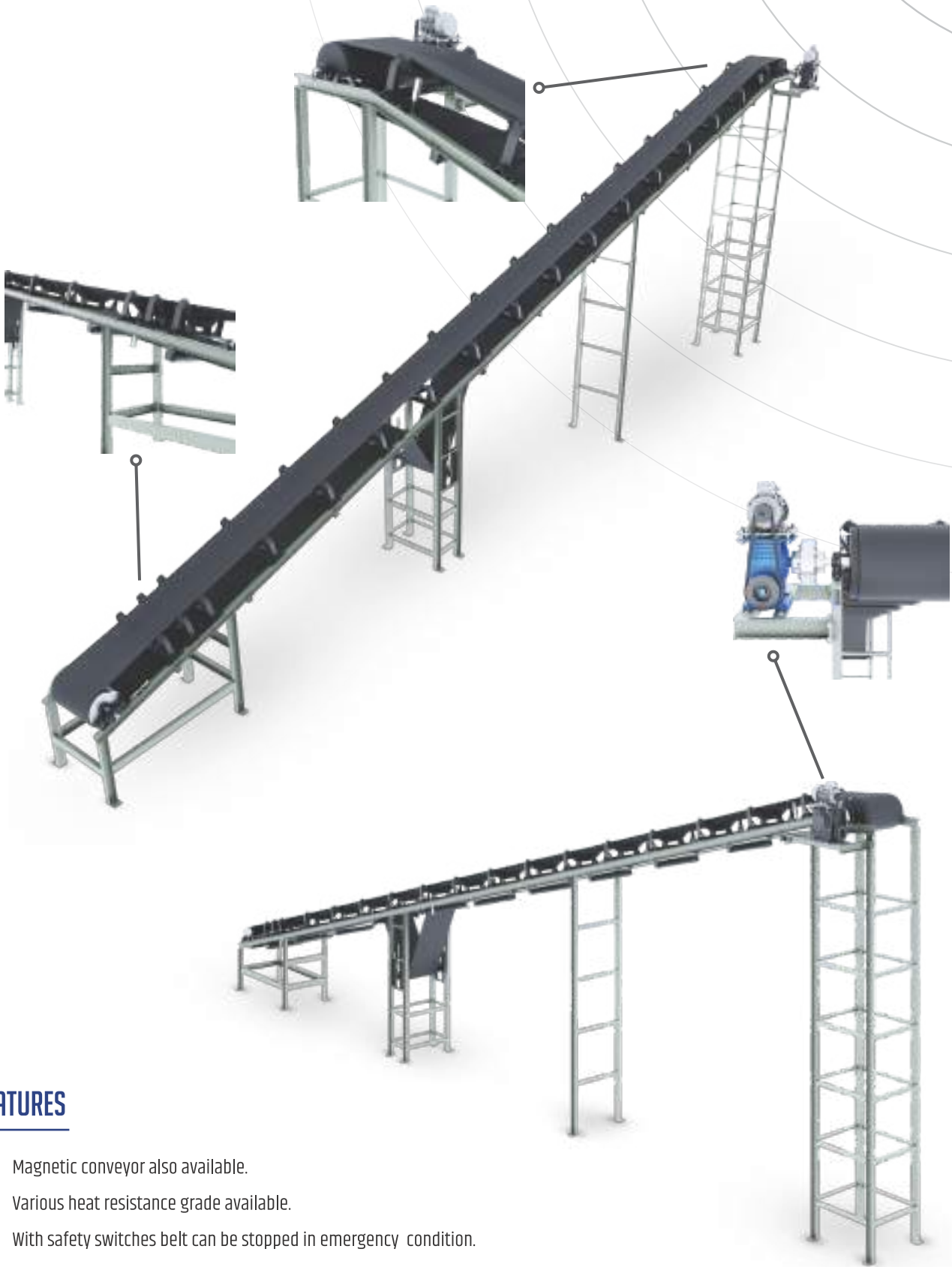

FEATURES

- ✓ Magnetic conveyor also available.
- ✓ Various heat resistance grade available.
- ✓ With safety switches belt can be stopped in emergency condition.
- ✓ Heavy and robust design.
- ✓ Size and capacity as per customer requirements.



BUCKET ELEVATOR

Sand Casting Equipments
GREEN SAND PROCESS



FEATURES

- ✓ Various heat resistance grade available .
- ✓ They are compact hence they use less ground space.
- ✓ Easy to install design.
- ✓ Heavy and robust design.
- ✓ Size and capacity as per customer requirements.



POLYGONAL SAND SIEVER

Sand Casting Equipments
GREEN SAND PROCESS

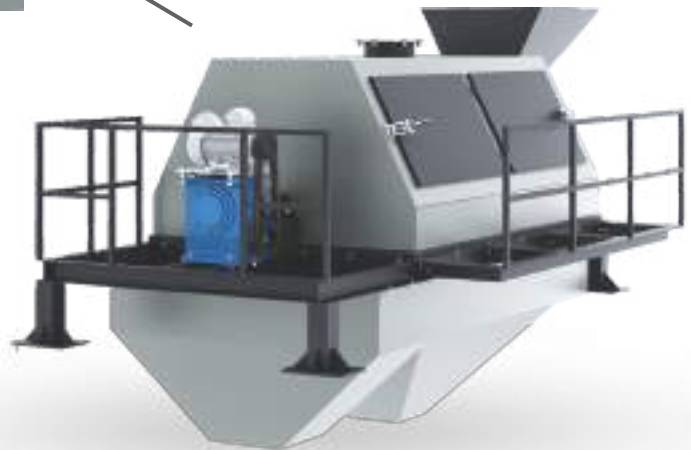

FEATURES

- ✓ Hexagonal Type For Better Performance
- ✓ Dust Extraction Point
- ✓ Size & Capacity As Per Customer Requirement



GREEN SAND PROCESS SUPER COOLER

Sand Casting Equipments
GREEN SAND PROCESS

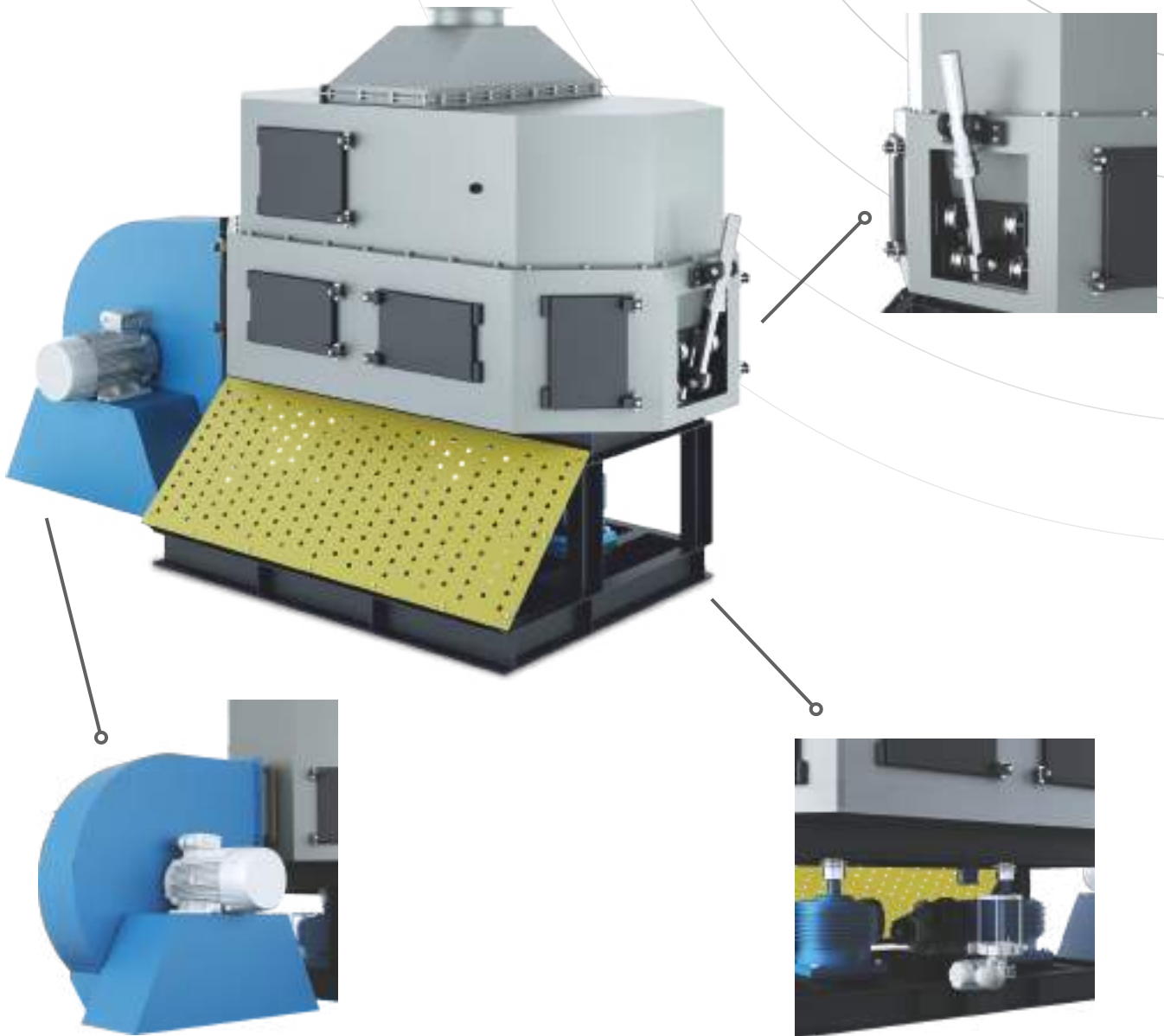

FEATURES

- ✓ Cooler Chamber Covered By Wear Resistance Material For Better Life.
- ✓ Require Output Temperature Achieve Through Air And Water.
- ✓ High Efficiency In Cooling.
- ✓ Consistency In Sand Temperature And Moisture.
- ✓ Robust In Design.





ALFA FOUNDRY TECHNOLOGIES PVT. LTD.

Sugam Industrial Area, Survey No. 220-221-222, Plot No. 3 to 6,
Naranka - Padavla Road, Village - Naranka, Taluka - Kotda Sangani, Rajkot - 360 030. (Gujarat-India)

Contact Number

+91 81403 49494

+91 98793 49494

Email Address

alfarajkot@yahoo.com

gr@aftpl-rajkot.com

Website

www.aftpl-rajkot.com